

A River Knits design exclusive!

Free pattern. Please purchase yarn at River Knits.



Gaea Creations



Baby Sweater and Hat

Materials: approximately 500 yards of worsted weight yarn, size 8 needles, 3 buttons.

Finished Measurements:

To fit a 6 to 12 month old baby

Chest: 24"

Length: 11"

Gauge: 20 sts and 28 rows to 4 inches in stockinette stitch.

Special Techniques:

All techniques are taught in the Learn To Knit classes offered at River Knits yarn shop in Lafayette, IN. If any of the techniques are unfamiliar to you, we'd love to have you attend a class. You could also consult one of the books listed under "References."

The Baby Sweater:

Back:

Cast on 54 sts. Work Garter Stitch (knit every row) for 1 1/2 inches (6 ridges). Increase 6 stitches evenly spaced (in this case, you would (K8, M1) 6 times, knit to end). Work Stockinette Stitch (knit one row, purl one row) until piece measures 11 inches from cast on edge.

Shape Shoulder Button Band:

On the next Wrong Side (or purl) row, Knit 17 sts, turn. Knit to end of row, turn. Continue to work Garter Stitch on these 17 stitches until you have 2 ridges. Bind off only these 17 sts on the wrong side.

Front:

Cast on 54 sts. Work Garter Stitch (knit every row) for 1 1/2 inches (6 ridges). Increase 6 stitches evenly spaced (in this case, you would (K8, M1) 6 times, knit to end). Work Stockinette Stitch (knit one row, purl one row) until piece measures 9 inches from cast on edge.

Shape Neck:

On next Right Side (or knit) row, knit 22 stitches and slip these stitches to a holder (left shoulder stitches). Knit the next 16 stitches and slip these to another holder (front neck stitches), knit to end.

Shape Right Neck edge/shoulder:

Row 1: Purl

Row 2: Knit 1, ssk, knit to end.

Repeat these two rows until 17 stitches remain.

Continue in stockinette on these 17 stitches until piece measures 11 inches from cast on edge. Slip stitches to a holder.

Shape Left Neck edge/shoulder:

Pick up left shoulder stitches from holder. Join yarn to begin with a purl row.

Row 1: Purl.

Row 2: Knit to last three stitches, k2tog, knit 1.

Repeat these two rows until 17 stitches remain.

Continue in stockinette on these 17 stitches until piece measures 11 inches, ending with a knit row.

Shape Shoulder Button Band:

On next Wrong Side row, knit.

Next row: K5, YO, k2tog, K4, YO, K2tog, K4.

Continue in garter stitch until you have worked a total of two ridges. Bind off on wrong side.

Sleeve: (make 2)

Cast on 32 sts. Work k2, p2 rib for 1 1/2 inches. On the next Right Side row, increase 8 stitches, evenly spaced: K2, M1, (K4, M1) 7 times, K2. Continue in stockinette stitch, increasing one stitch each side every 4 rows 5 times. (50 stitches) Continue until piece measures 6 1/2 inches from cast on edge.

Neck Ribbing:

Using three-needle bind off, join right shoulder seam.

Pick up neck stitches: Beginning at the left front

shoulder with right side facing, pick up 12 stitches. Knit across held front stitches as follows: K3, k2tog, K4, k2tog, K3, k2tog. Continue by picking up 12 stitches to right shoulder. Knit across held back stitches as follows: K2, k2tog, (K5, k2 tog) 3 times, K1. Continue by picking up 3 stitches along side of left shoulder flap. (62 stitches total picked up). Do not join. Ribbing is worked back and forth. Ribbing Set Up Row (wrong side): P2, (K2, P2) to end. Next row (right side), K2, yarn over, p2tog, work in rib as established to end. Continue in pattern for 3 more rows (5 rows of ribbing total). Bind off in pattern.

Finishing:

On left shoulder, tack button bands together where they will meet the arm. Attach sleeves to body: Lay body of sweater flat on a flat surface. Measure 5" down from right shoulder and mark this point on the front and back. Pick up 50 sts between these two points. Join the sleeve using three-needle bind off. Repeat this process on the left shoulder. Sew side seams. Weave in all yarn ends. Sew buttons onto button band. Dress your favorite baby in the sweater and admire your work!

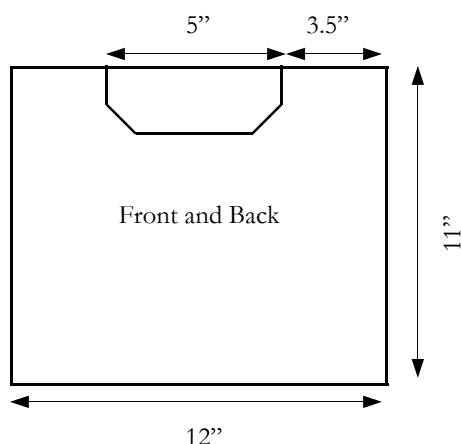

The Matching Hat:

Using a 16" circular needle, cast on 84 stitches. Place marker and join, being careful not to twist. Knit every round until piece measures 6". Shape top of hat as follows, changing to double pointed needles as needed:
 Round 1: (K10, k2 tog) around.
 Round 2 (and all even rounds): Knit.
 Round 3: (K9, k2tog) around.
 Round 5: (K8, k2tog) around.
 Round 7: (K7, k2tog) around.
 Now, begin working the decreases every round as follows:
 Round 8: (K6, k2tog) around.
 Round 9: (K5, k2tog) around.
 Round 10: (K4, k2tog) around.
 Round 11: (K3, k2tog) around.
 Round 12: (K2, k2tog) around.
 Round 13: (K1, k2tog) around.
 Round 14: k2tog around.

Finish by running the yarn through the remaining stitches and pulling tightly to close the opening at the top. Leave as is, or top it with a tassel, pompon or other jaunty decoration.

Enjoy!

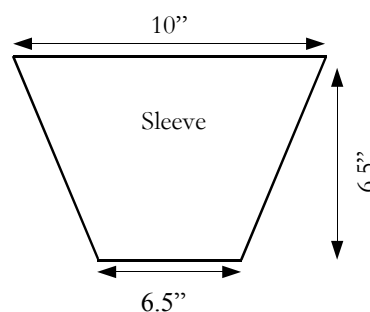

References:

Buss, Katharina. *Big Book of Knitting*. New York: Sterling Publishing Company, Inc., 2001.
 Crowfoot, Jane. *All Stitched Up*. Hauppauge: Barron's Educational Series, Inc., 2003.
 Vogue Knitting. *Vogue Knitting: The Ultimate Knitting Book*. New York: Pantheon Books, 1989.